

Quench 952

Freestanding Water and Ice Dispenser

- Dispenses cold, hot, and room temperature water
- Produces up to 44 lbs. of tulip-shaped ice in 24 hours*
- Stores up to 8.8 lbs. of ice
- Advanced reverse osmosis filtration technology
- Touchless sensor dispensing
- In-tank and in-storage bin LED UV to maintain cleanliness
- Taller ergonomic height for no-bend dispensing



water up

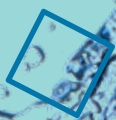
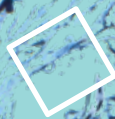



Quench 952

Enhance your guests, clients, and employees' hydration experience by offering ice from the Quench 952! The Quench 952 offers cold, hot, and ambient filtered drinking water as well as tulip-shaped ice on-demand. With its dual LED UV-C light to maintain cleanliness, antimicrobial surface protection, and touchless sensor dispensing, the Quench 952 offers advanced hygienic features and peace of mind from cross-contamination. The Quench 952 fits in any break room, office kitchen, or waiting room with a sleek glass front and ergonomic no-bend design.



Contemporary Design with Advanced Features

- Single spout for cold, hot, and room temperature water
- Produces 44 lbs. of tulip-shaped ice per day*
- Stores up to 8.8 lbs. of ice
- Large 10" dispensing area
- Hot water safety dispensing
- Reverse osmosis filtration
- Sanitary touchless sensor dispensing
- Antimicrobial surface protection
- Taller no-bend ergonomic design
- Dual LED UV-C light to maintain water cleanliness
- Leak protection system
- Energy-efficient operation

Specifications

Dimensions	58.7" h x 16.9" w x 19.4" d / 149.1 cm h x 43 cm w x 49.3 cm d
Dispensing Area	10" / 25.4 cm
Weight	119.5 lbs / 54.3 kg
Cold Tank Capacity	1.2 gallons / liters
Hot Tank Capacity	1.2 gallons / liters
Ambient Tank Capacity	4.5 gallons / liters
Ice Output	44 lbs / day (20 kg/day)*
Ice Storage	8.8 lbs / 4 kg
Recommended Water Pressure	40-70 PSI
Rated Voltage/Frequency	110v/60Hz
Power Consumption	6.5 amps (2.83 kWh/24 hours)
Drainage	Drain required within 20 ft.
Model Number	952

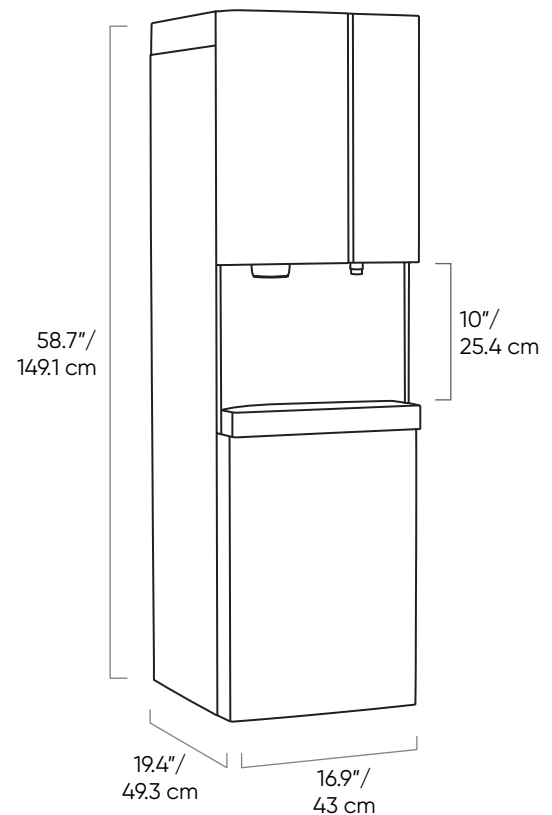

* Quench products are certified by independent authorized 3rd party laboratories in accordance of appropriate industry standards. To find out more about which certifications your product may have, please contact us.